

# ECLIPSE MARK IV COMBINATION GAS/OIL BURNER

SERIES "MF"

Low NO<sub>x</sub> and CO!

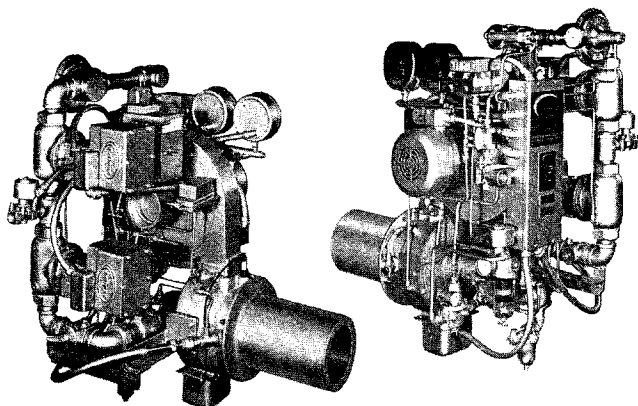

100 & 200 CGO-IRI

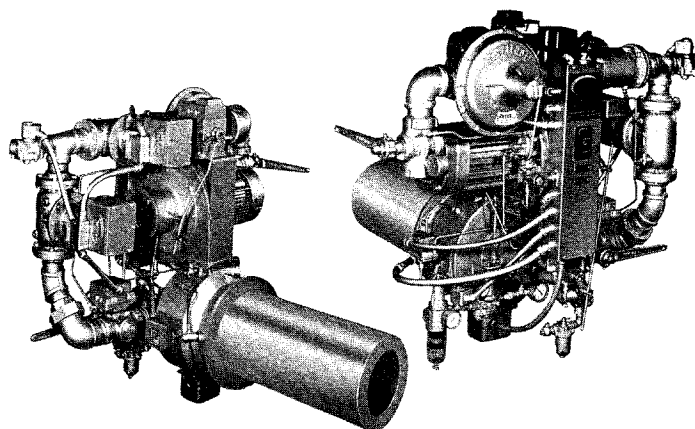

300 & 500 CGO-IRI

Eclipse Mark IV Burners are packaged, nozzle-mixing, combination gas/oil burners for use in process heating applications with specific emphasis on ovens and dryers. Mark IV burners can be used with any commercially available fuel gas and with fuel oils up to and including #2 oil. The hot products of combustion produced are clean, (less than #1 Ringleman even with #2 fuel oil) ready to be used for drying, baking or curing a wide variety of products. Mark IV burners have been used to dry paint (all colors), paper and paper products, cloth (all colors), food products, ink, laminates, packaging film, carpets and a wide variety of other products. In addition, the Mark IV is capable of firing boilers, furnaces, incinerators, metal melters and other equipment requiring a combustion block. Four burner sizes are available with maximum capacities from 1,000,000 to 5,000,000 Btu/hr.

## OPERATION

After the complete burner package is bolted to the appliance it is only necessary to connect the gas, oil, and atomizing air lines and wire the terminal strip to a suitable control panel. (Control panels are also available from Eclipse to meet the particular needs of the application.)

A mounting flange is provided to simplify the installation of the burner and firing tube. Usually a light weight high alloy, heat resistant tube is used to direct the flame in the appliance. However, for furnaces or other high temperature firing conditions, a refractory combustion block can be supplied. Four different types of firing tubes are available for use with the Mark IV Burner: The standard tube for applications that do not require modification of normal flame length, direction or shape; The Flame Spreader tube that reduces the flame length to less than one half the length achieved with the standard tube. This helps prevent flame impingement when the burner is used in applications where space for forward flame travel is limited; The 90° firing tube which is designed for applications where it is desirable to mount the burner perpendicular to the air flow while firing with the air flow; The 90° Flame Spreader which combines the features of the preceding two firing tubes.

The Mark IV can be mounted on the pressure or suction side of the fan and can be fired with or across the airstream. Recom-

mend duct pressure limits are -4" w.c. to +1" w.c. using the standard blower. Two optional blowers are available to fire with duct pressures up to 8" w.c. See burner selection charts pages 2 and 3. When burner is fired across the duct, without the use of the 90° firing tube, the air velocity in the duct should be limited to 1000 fpm and the flame should not be allowed to impinge on the duct at any point.

## ADVANTAGES

- • • Easily installed.
- • • Heavy duty construction.
- • • Wide turndown range.
- • • Dual fuel capability.
- • • Suitable for pressure or suction firing.
- • • Variety of firing tubes available.
- • • All burners pre-tested and tagged.
- • • Easily adjusted.
- • • Complete units pre-wired, pre-piped and test fired.
- • • Extremely clean burning.

## ASSEMBLIES

Basic and Complete versions of the Mark IV burner are available in oil, gas, straight gas, and combination gas/oil configurations. Gas models contain oil internals for possible later conversion to oil, while straight gas models do not. Basic Mark IV assemblies are supplied with an integral combustion air blower, linkage for connecting the air control valve to a control motor, bypass pilot piping, ignition plug, and an oil metering valve when applicable. Separate valve trains for use with basic assemblies are shown on page 7.

The complete burner package can be selected to include FM or IRI gas valves, oil valves, full pre-packaging with full wiring, piping, control motor (air or electric) and flame sensing device. All Mark IV burners can be ordered less blower.

## IGNITION AND FLAME MONITORING

Ignition of the gas by-pass pilot is by direct spark. Once the pilot flame is proven, the main fuel valve (gas or oil) opens and the main flame is established. After an overlap period (approximately 5 seconds) the pilot flame may be shut off. Full modulation of fuel and air is then controlled by the temperature controller and a suitable control motor. The control



**ECLIPSE COMBUSTION**

motor linkage can be adjusted so that the burner will operate with a set percent of excess air throughout the operating range, or "on-ratio".

**CAUTION:** The Mark IV burner is not equipped with flame monitoring devices. It is dangerous to use any fuel burning equipment unless it is equipped with suitable flame monitor-

ing device(s) and automatic fuel shut-off valve(s). Eclipse can supply such equipment or information on alternate sources. The owner/user and/or his insurance underwriter must assume responsibility for the acceptance, use and proper maintenance of flame supervision, limit controls and other safety devices that may be used with the Mark IV burner.

### CAPACITIES

	MODEL	NAT. GAS .65 SP. GR.	#2 FUEL OIL
Maximum Cap.—Btu/hr.	100-MF	1,000,000	1,000,000
	200-MF	2,000,000	2,000,000
	300-MF	3,000,000	3,000,000
	500-MF	5,000,000	5,000,000
Minimum Cap. Btu/hr.	100-MF	50,000*	76,000
	200-MF	125,000*	133,000
	300-MF	125,000	150,000
	500-MF	150,000*	250,000
Min.-Max. Fuel Pressure to Valve Train Inlet ("Complete" versions ONLY)	100-MF	14"-28" w.c.	75-100 psig
	200-MF		75-100 psig
	300-MF		75-100 psig
	500-MF		75-100 psig
Fuel Pressure Req'd. to Burner Body Tap (Gas) or to Oil Metering Valve ("Basic" versions ONLY)**	100-MF	6.0" w.c.	60 psig
	200-MF	10.6" w.c.	60 psig
	300-MF	5.8" w.c.	60 psig
	500-MF	4.6" w.c.	60 psig

\*Pilot input

\*\*Pressures indicated are approximate *ONLY* and will vary with each application.

### ATOMIZING AIR REQUIREMENTS

MODEL	PRESSURE REQ'D. TO VALVE TRAIN INLET (MF "COMPLETE")	FLOW REQ'D. (SCFM)
100-MF	65-100 psig	3.25
200-MF	65-100 psig	3.25
300-MF	65-100 psig	13.00
500-MF	65-100 psig	14.5

### FLAME LENGTHS

MODEL	APPROX. HIGH FIRE FLAME LENGTH WITH STRAIGHT TUBE
100 MF	24"
200 MF	36"
300 MF	42"
500 MF	54"

## MARK IV BURNER AND PARTS GROUP SELECTION INFORMATION

Select burner based on capacity requirements, type of fuel to be used and insurance requirements. Select desired firing tube or block and holder. Determine duct pressure rating and select suitable blower. Select drive motor and specify motor operation parts group. Determine flame safety system and select compatible scanner and mounting parts group. If insurance requirements indicate the low fire start position must be proven, select optional low fire micro switch.

EXAMPLE: 1mm Btu/hr Combination gas/oil, IRI burner, 90° firing, air operated temperature control, PCI flame safety,

5" w.c. back pressure, 60 cy. operation, proven low fire start.

Order as follows:

- (109643) 100 MF-CGO-IRI less
- (109635) Standard Blower with
- (109933) Optional Blower I with
- (109609) 100 MF-90 firing tube with
- (109911) Air operator mounting parts group with
- (12851) Air operator with
- (109950) PCI scanner and mounting parts group with
- (109907) Low fire micro switch.

### MARK IV BURNER CONFIGURATIONS WITH BLOWER

CAT. NO.	OIL		COMB. GAS/OIL (CGO)			STRAIGHT GAS (SG)			GAS (G)		
	BASIC	COMP.	BASIC	COMP. FM	COMP. IRI	BASIC	COMP. FM	COMP. IRI	BASIC	COMP. FM	COMP. IRI
100 MF	109640	109642	109641	109644	109643	106349	—	—	106337	—	—
200 MF	109636	109646	109638	109689	109688	106350	—	—	106336	—	—
300 MF	109624	109625	109634	109627	109626	106351	—	—	106338	—	—
500 MF	109902	109904	109903	109905	109906	106352	—	—	106339	—	—

Consult factory for models with unlisted assembly numbers. FM type burners may or may not meet local standards. Check current standards before ordering.

## MARK IV BURNER CONFIGURATIONS LESS BLOWER\*

CAT. NO.	OIL		COMB. GAS/OIL (CGO)			STRAIGHT GAS (SG)			GAS (G)		
	BASIC	COMP.	BASIC	COMP. FM	COMP. IRI	BASIC	COMP. FM	COMP. IRI	BASIC	COMP. FM	COMP. IRI
100 MF-LB	106300	106302	106301	106303	106304	—	—	—	—	—	—
200 MF-LB	106305	106308	106307	106310	106311	—	—	—	—	—	—
300 MF-LB	106313	106315	106314	106316	106317	—	—	—	—	—	—
500 MF-LB	106318	106320	106319	106321	106322	—	—	—	—	—	—

Consult factory for models with unlisted assembly numbers. FM type burners may or may not meet local standards. Check current standards before ordering.

### BLOWER OPTIONS

FOR BURNER CAT NO.	STANDARD BLOWER*		OPTIONAL BLOWER I		OPTIONAL BLOWER II	
	ASSY. NO.	HORSEPOWER	ASSY. NO.	HORSEPOWER	ASSY. NO.	HORSEPOWER
100 MF	109635	3/4	109933	3/4	109908	1
200 MF	109631	1	109935	1-1/2	109760	1-1/2
300 MF	109621	2	109937	3	109800	3
500 MF	109943	3	109939	5	109818	5

Mark IV burners ordered with blower normally include the Standard Blower. If optional Blower I or II is required, delete the assembly number of the Standard Blower and add the assembly number of the Optional Blower.

### DUCT PRESS. RATINGS FOR MARK IV BLOWERS

BLOWER TYPE	MAX. DUCT PRESSURE	
	60 Hz MOTOR	50 Hz MOTOR
Std. Blower	+ 1" W.C.	- 2" W.C.
Opt. Blower I	+ 5" W.C.	+ 1" W.C.
Opt. Blower II	+ 8" W.C.	+ 4" W.C.

### AVAILABLE SCANNERS AND MOUNTING PARTS GROUPS\*

FOR BURNER CAT. NO.	ASSEMBLY NUMBER		
	PCI	HONEYWELL	FIREYE
100 thru 500 MF	109950	109949	109948

\*Includes scanner and necessary parts required to mount on the burner.

### OPTIONAL LOW FIRE MICRO SWITCH\*

FOR BURNER CAT. NO.	ASSEMBLY NUMBER
100 thru 500 MF	109907

\*Normally used with air operation to prove low fire start position.

### MOTOR OPERATOR PARTS GROUP\*

FOR BURNER CAT. NO.	ASSEMBLY NUMBER	
	ELECTRIC	AIR
100 thru 500 MF	109854	109911

\*Includes base and linkage and mounting of the selected drive motor on the burner.

### ELECTRICAL DRIVE MOTORS AVAILABLE FOR USE WITH ASSY. NO. 109854 ELECTRIC OPERATOR PARTS GROUP

PART NUMBER	DESCRIPTION
10826	Two Position Control—Honeywell M644-1024 (formerly M604C). 30 second timing, 90° stroke, 24 volt. Includes crank arm with motor. Requires 120 or 240 volt transformer.
15433	Proportioning Control—Honeywell M941A-1057. 15 second timing, 90° stroke, 24 volt. Includes crank arm with motor. Requires 120 or 240 volt to 24 volt transformer.
12200	Proportioning Control—Honeywell M7445-100S. 30 second timing, 90° stroke, 150 in. lb. torque, 4-20 ma input.
12622	Proportioning Motor—Eclipse EMP-424-1. Adjustable speed, 90° stroke, 12 second timing for fastest speed, 60 in. lb. torque. For 124 volt, 60 hertz.
16107	Proportioning Control—Honeywell M941A-1024. 60 second timing, 90° stroke, 24 volt. Includes crank arm with motor. Requires 120 or 240 volt to 24 volt transformer.
12632	Proportioning Motor—Eclipse EMP-453-1. Fixed speed, 90° stroke, 40 second timing, 220 in. lb. torque. For 120 volt, 60 hertz.
12634	Proportioning Motor—Eclipse EMP-454-1. Adjustable speed (40 to 300 seconds), 90° stroke, 220 in. lb. torque. For 120 volt, 60 hertz.

### AIR OPERATORS AVAILABLE FOR USE WITH ASSEMBLY NO. 109911 AIR OPERATOR PARTS GROUP

PART NUMBER	DESCRIPTION
12476	Pneumatic Actuator—Honeywell 8610314-107 Short Lever Model Air-O-Motor, Type 03 with positioner, direct acting. Supply air pressure 18 to 25 psig for 3 to 15 psig instrument air.
12851	Pneumatic Actuator—Honeywell 8610314-108 Short Lever Model Air-O-Motor, Type 03 less positioner, for 3 to 15 psig instrument air.
CON	Pneumatic Actuator—Fisher Lever Model 658-2.
CON	Pneumatic Actuator—Conoflow B1OL.

**NOTE:** The above Honeywell operators are pneumatic actuators for use on 3 to 15 psi instrument air signal. They have a lever arm stroke length from 3-1/4" to 4-5/16", depending on hole used.

# DIMENSIONS

## COMBINATION GAS/OIL BASIC

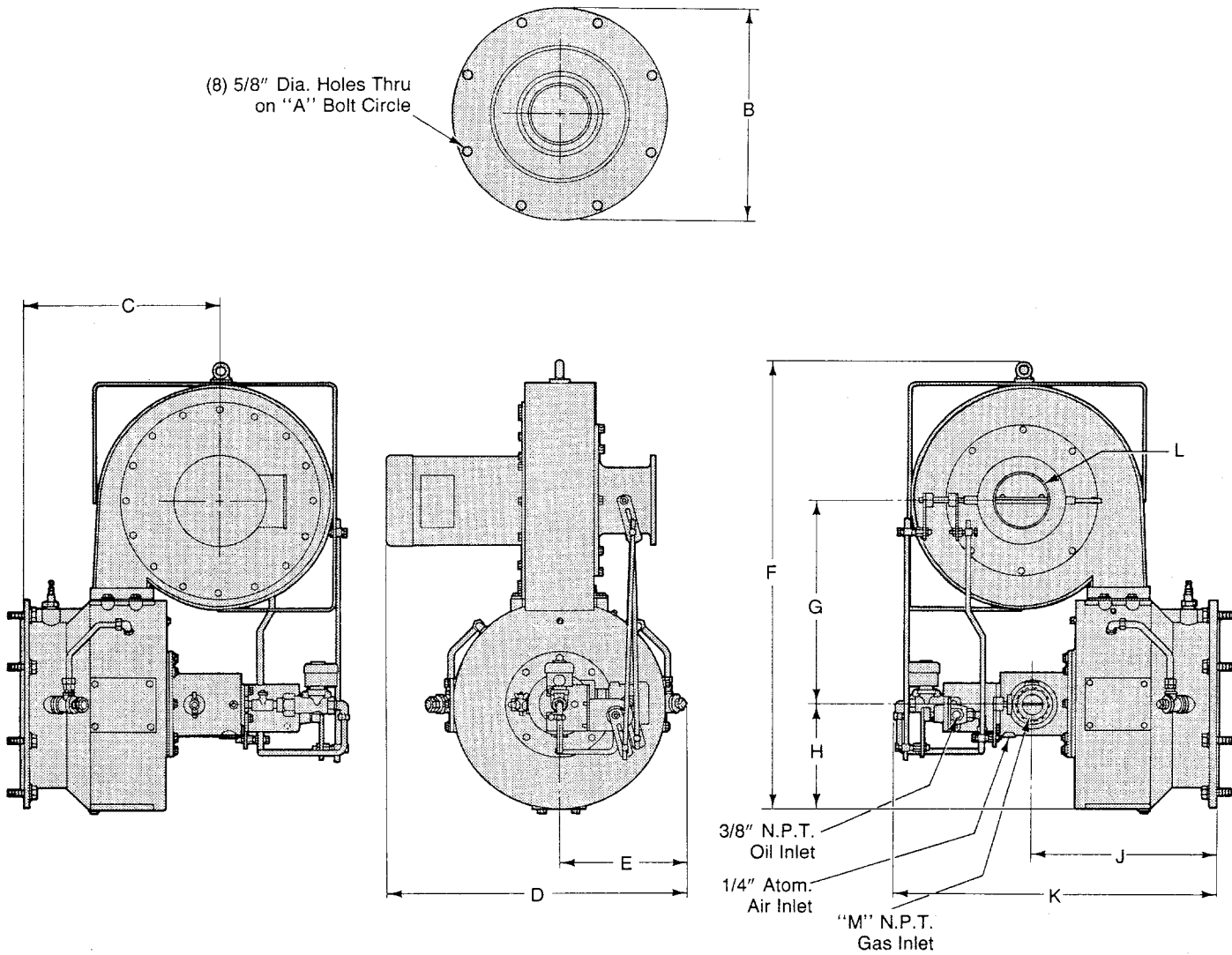

BURNER CAT. NO.	DIMENSIONS											
	A	B	C	D	E	F	G	H	J	K	L*	M
100 MF	10-1/2	11-3/4	11-1/4	21-15/16	9-7/16	30-1/4	13-3/4	6-1/4	10-1/8	20-5/8	3	1
200 MF	10-1/2	11-3/4	11-1/4	21-5/8	9-5/8	30-1/4	13-5/8	5-7/8	10-1/8	20-1/2	4	1-1/2
300 MF	14-5/8	16	14-11/16	22-3/4	9-7/8	34-3/8	15-1/2	8	13-15/16	24-1/2	6	2
500 MF	14-5/8	16	14-11/16	25-1/2	9-7/8	34-3/8	15-1/2	8	13-15/16	24-1/2	7-1/4	2-1/2

\*100 & 200 Mark IV burners have threaded NPT combustion air inlets. The 300 & 500 Mark IV burners have (4) 1/4-20 holes on L bolt circle.  
**NOTE:** These drawings are intended only as approximate representations of the actual burners. For exact dimensional information and parts lists ask for the specification sheets listed on page 5.

# DIMENSIONS

## COMBINATION GAS/OIL COMPLETE IRI

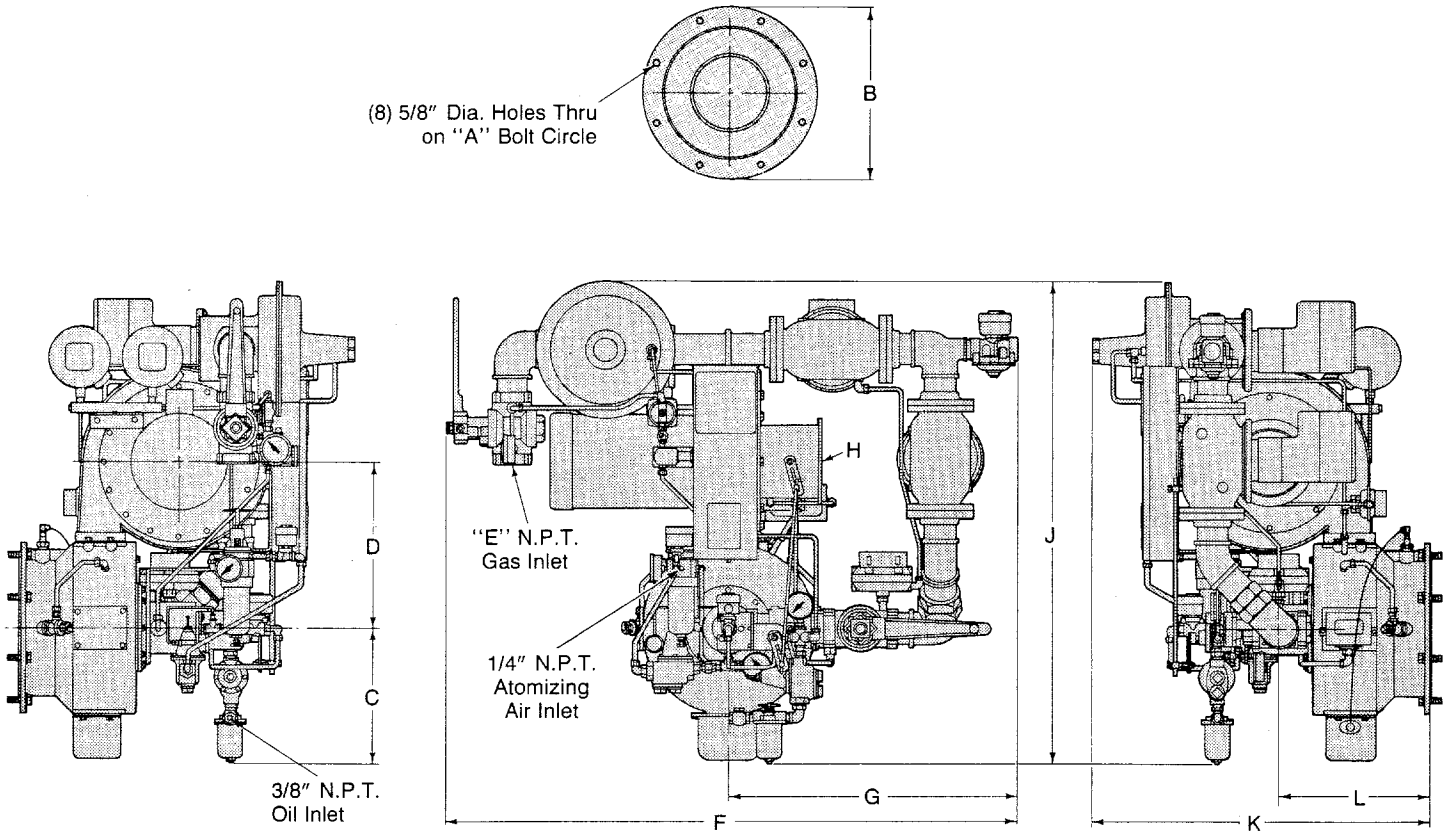

BURNER CAT. NO.	DIMENSIONS										
	A	B	C	D	E	F	G	H*	J	K	L
100 MF	10-1/2	11-3/4	12	13-3/4	1	27	13-1/2	3	40	25	10-1/8
200 MF	10-1/2	11-3/4	12	12-5/8	1-1/2	28	14	4	42-7/8	27	10-1/8
300 MF	14-5/8	16	12	15-1/2	2	38-7/8	18-1/4	6	51-1/16	29	13-15/16
500 MF	14-5/8	16	12	15-1/2	2-1/2	52-3/4	26-1/2	7-1/4	45	31-1/2	13-15/16

\* 100 & 200 Mark IV burners have threaded NPT combustion air inlets. The 300 & 500 Mark IV burners have (4) 1/4-20 holes on H bolt circle.  
**NOTE:** These drawings are intended only as approximate representations of the actual burners. For exact dimensional information and parts lists ask for the following specification sheets.

### SPECIFICATION SHEETS

BURNER TYPE	SPEC. SHEET	BURNER TYPE	SPEC. SHEET
100-MF-OIL BASIC	SP-246-1	300 MF-OIL BASIC	SP-246-15
100 MF-OIL COMP.	SP-246-2	300 MF-OIL COMP.	SP-246-16
100 MF-CGO BASIC	SP-246-3	300 MF-CGO BASIC	SP-246-17
100 MF-CGO-FM	SP-246-4	300 MF-CGO-FM	SP-246-18
100 MF-CGO-IRI	SP-246-5	300 MF-CGO-IRI	SP-246-19
100 MF-GAS BASIC	SP-246-6	300 MF-GAS BASIC	SP-246-20
100 MF-SG BASIC	SP-246-7	300 MF-SG BASIC	SP-246-21
200 MF-OIL BASIC	SP-246-8	500 MF-OIL BASIC	SP-246-22
200 MF-OIL COMP.	SP-246-9	500 MF-OIL COMP.	SP-246-23
200 MF-CGO BASIC	SP-246-10	500 MF-CGO BASIC	SP-246-24
200 MF-CGO-FM	SP-246-11	500 MF-CGO-FM	SP-246-25
200 MF-CGO-IRI	SP-246-12	500 MF-CGO-IRI	SP-246-26
200 MF-GAS BASIC	SP-246-13	500 MF-GAS BASIC	SP-246-27
200 MF-SG BASIC	SP-246-14	500 MF-SG BASIC	SP-246-28

## FIRING TUBES: GAS OR OIL

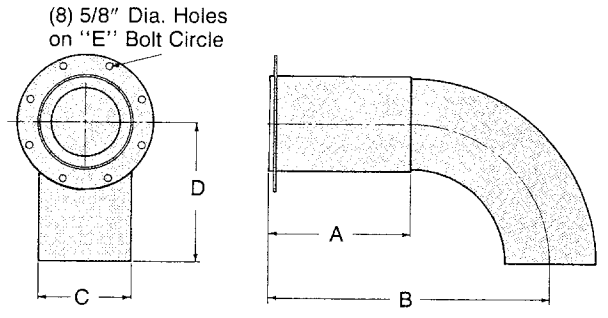
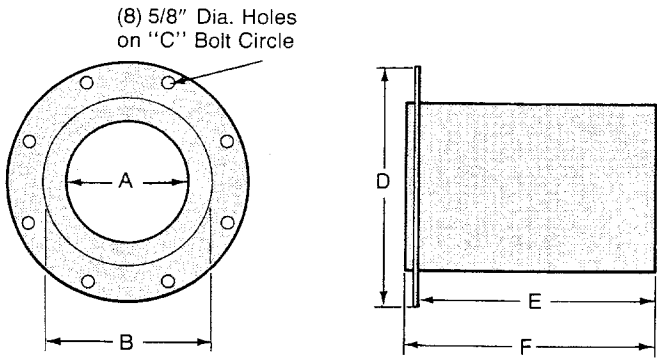

CATALOG NUMBER	ASSEMBLY NUMBER	DIMENSIONS (IN INCHES)					
		A	B	C	D	E	F
100 MF-ST	109986	5	6-1/8	10-1/2	11-3/4	11-5/8	12
200 MF-ST	109983	6	8-1/8	10-1/2	11-3/4	11-5/8	12
300 MF-ST	109607	8	10-1/8	14-5/8	16	23-5/8	24
500 MF-ST	109966	8	12-1/8	14-5/8	16	23-5/8	24

CATALOG NUMBER	ASSEMBLY NUMBER	DIMENSIONS (IN INCHES)				
		A	B	C	D	E
100 MF-90	109609	12	21	6	9	10-1/2
200 MF-90	109608	12	24	8	12	10-1/2
300 MF-90	109618	24	39	10	15	14-5/8
500 MF-90	109614	24	39-1/2	12	15-1/2	14-5/8

Max. Upstream Air Temp.: 500°F  
 Max. Downstream Air Temp.: 900°F

Max. Upstream Air Temp.: 500°F  
 Max. Downstream Air Temp.: 800°F

## PERFORATED FLAME SPREADERS: GAS OR OIL

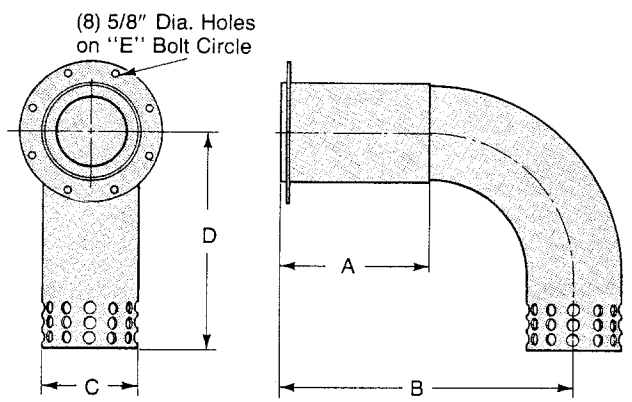
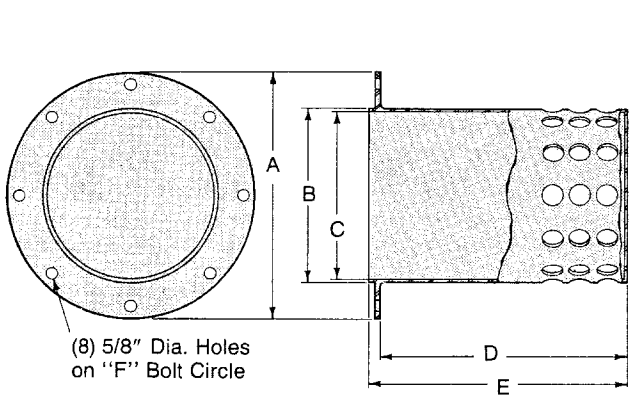

CATALOG NUMBER	ASSEMBLY NUMBER	DIMENSIONS (IN INCHES)					
		A	B	C	D	E	F
100 MF-FS	109999	11-3/4	6-1/8	6	11-1/2	12	10-1/2
200 MF-FS	109604	11-3/4	8-1/8	8	11-1/2	12	10-1/2
300 MF-FS	106340	16	10-1/8	10	23-1/2	24	14-5/8
500 MF-FS	106341	16	12-1/8	12	23-1/2	24	14-5/8

CATALOG NUMBER	ASSEMBLY NUMBER	DIMENSIONS (IN INCHES)				
		A	B	C	D	E
100 MF-90-FS	109042	12	21	6-1/8	15-3/4	10-1/2
200 MF-90-FS	109043	12	24	8-1/8	19	10-1/2
300 MF-90-FS	109044	24	39	10-1/8	22-1/4	14-5/8
500 MF-90-FS	109045	24	42	12-1/8	27-3/4	14-5/8

Max. Upstream Air Temp.: Ambient  
 Max. Downstream Air Temp.: 500°F

Max. Upstream Air Temp.: Ambient  
 Max. Downstream Air Temp.: 500°F

## FLAME SHAPES

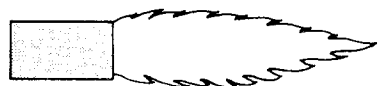

**STANDARD TUBE & BLOCK AND HOLDER**



**90° TUBE**

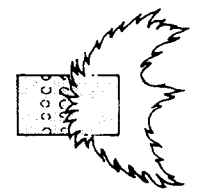

**FLAME SPREADER & 90° FLAME SPREADER**

## SLOTTED FLAME SPREADERS: GAS ONLY

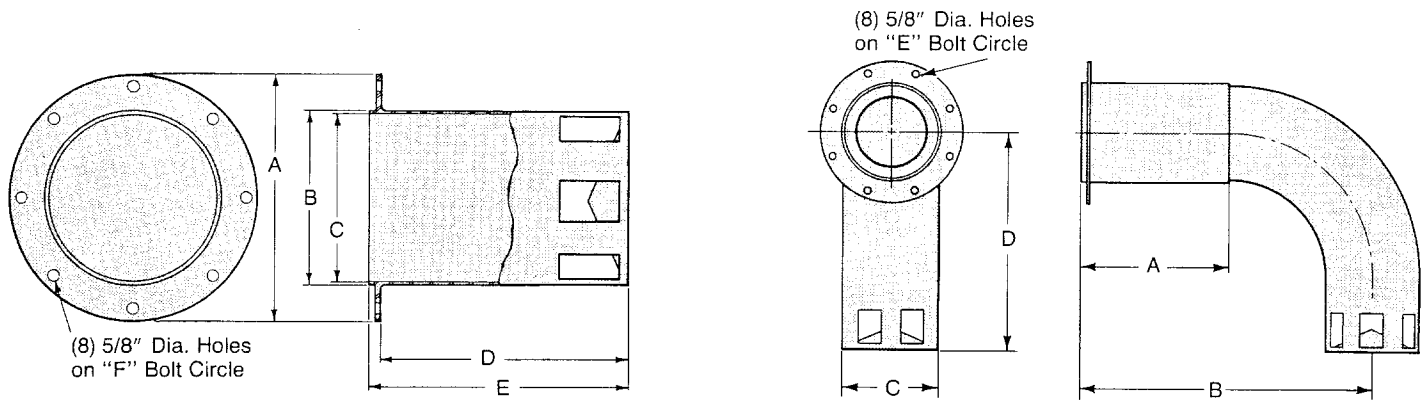

CATALOG NUMBER	ASSEMBLY NUMBER	DIMENSIONS (IN INCHES)					
		A	B	C	D	E	F
100 MF-SFS	106207	11-3/4	6-1/8	6	11-1/2	12	10-1/2
200 MF-SFS	106209	11-3/4	8-1/8	8	11-1/2	12	10-1/2
300 MF-SFS	106211	16	10-1/8	10	23-1/2	24	14-5/8
500 MF-SFS	106213	16	12-1/8	12	23-1/2	24	14-5/8

Max. Upstream Air Temp. 500°F  
Max. Downstream Air Temp. 800°F

CATALOG NUMBER	ASSEMBLY NUMBER	DIMENSIONS (IN INCHES)				
		A	B	C	D	E
100 MF-90-SFS	106208	12	21	6-1/8	15-3/4	10-1/2
200 MF-90-SFS	106210	12	24	8-1/8	19	10-1/2
300 MF-90-SFS	106212	24	39	10-1/8	22-1/4	14-5/8
500 MF-90-SFS	106214	24	42	12-1/8	27-3/4	14-5/8

Max. Upstream Air Temp.: 500°F  
Max. Downstream Air Temp.: 800°F

## BLOCK & HOLDER ASSEMBLIES

FOR 100 & 200 MF

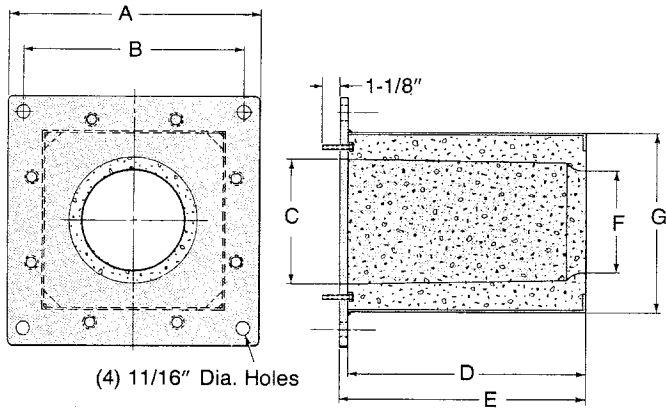

FOR 300 & 500 MF

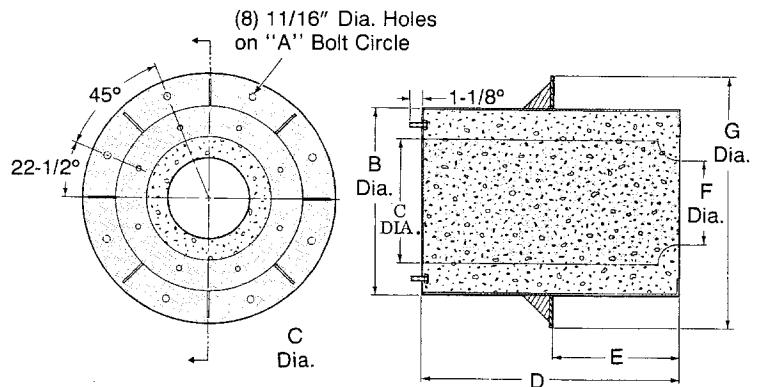

CATALOG NUMBER	ASSEMBLY NUMBER	DIMENSIONS (In Inches)						
		A	B	C	D	E	F	G
100 MF-BH-S	180240-	12	10-1/2	6-1/32	11-3/8	11-3/4	5	8-5/8
200 MF-BH-S	180241-	15	13	8-1/64	11-1/2	11-7/8	6	11

CATALOG NUMBER	ASSEMBLY NUMBER	DIMENSIONS (In Inches)						
		A	B	C	D	E	F	G
300 MF-BH-R	180242-	19	16	10-1/2	24	12	8	22
500 MF-BH-R	180243-	21	18	12-1/2	24-1/2	12	8	24

Blocks are available in -61, -62, -71, and -72 materials listed below.

## MATERIAL DESIGNATIONS

DASH NO.	TRADE NAME AND DESCRIPTION	PCE CONE	% ALUMINA	MFG. MAX. OPERATING TEMP. °F.	RECOMMENDED USE TEMP. °F. CHAMBER
-61	Morocast 3000 HS with RA330 Stainless Block Wrapper, cast in wrapper	—	53	—	1400
-62	Morocast 90 HS with RA330 Stainless Block Wrapper, cast in wrapper	—	90+	—	1400
-71	Morocast 3000 HS with Ribtec OS fibers and RA330 Stainless Block Wrapper, cast in wrapper	—	53	—	1400
-72	Morocast 90 HS with Ribtec OS fibers and RA330 Stainless Block Wrapper, cast in wrapper	—	90+	—	1400

# PACKAGED VALVE TRAINS FOR BASIC MARK IV BURNERS

## MAIN GAS VALVE TRAIN-FM OR IRI

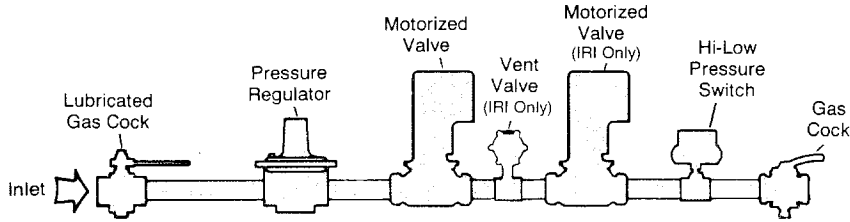

## PILOT GAS VALVE TRAIN

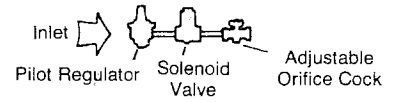

## OIL VALVE TRAIN

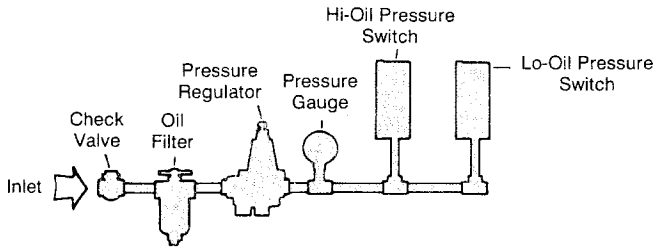

## ATOMIZING AIR VALVE TRAIN

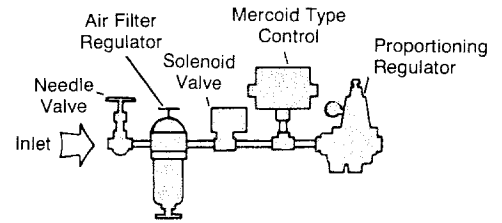

VALVE TRAIN	ASSEMBLY NUMBER	N.P.T. INLET	MAX. LENGTH
Main Gas (FM)	500077-3	1"	27-7/8"
	500078-3	1-1/2"	33-1/4"
	500079-3	2"	35-13/16"
	500080-3	2-1/2"	44-3/8"
Main Gas (IRI)	500073-1	1"	39-3/4"
	500074-1	1-1/2"	46-7/8"
	500075-1	2"	49-5/16"
	500076-1	2-1/2"	61-7/8"
Pilot Gas	500064	1/2"	7-15/16"
Oil	500081	3/8"	20-5/16"
Atomizing Air	500082	1/4"	21-1/4"

Maximum length is measured from valve train inlet to valve train outlet. When these assemblies are shipped with a Basic Burner they are not attached to the burner. The connection of the valve train to the burner is the customer's responsibility. All piping must conform to the requirements of the insurance carrier or local authority having jurisdiction. Factory packaged burners include assembly and interconnection of these components to the Basic burner.



**ECLIPSE COMBUSTION**





**Offered By:**

Power Equipment Company  
2011 Williamsburg Road  
Richmond, Virginia 23231  
Phone (804) 236-3800  
Fax (804) 236-3882

---

[www.peconet.com](http://www.peconet.com)